



**Installation and Operation Manual  
for Perenio® PECSS01  
Smoke Sensor**



## Introduction

The Smoke Sensor is a device that provides for timely detection of visible smoke particles in the area of installation. It can be used as a part of the **Perenio Smart Building Management System** after being connected via the Control Gateway/IoT Router, or as a standalone smoke alarm device.

The present Manual contains a detailed description of the Smoke Sensor, as well as instructions for its installation and operation.

## Copyrights

Copyright of ©Perenio IoT spol s r.o. All rights reserved.

The **Perenio**<sup>®</sup> trademark is owned by *Perenio IoT spol s r.o.* (hereinafter referred to as the *Perenio IoT*). All other similar trademarks and names, as well as logos and other symbols are the property of their respective owners\*.

All materials under **Perenio**<sup>®</sup> tradename contained therein are protected in accordance with international and local laws including Acts on copyrights and related rights.

Any reproduction, copying, publication, as well as further distribution or public display of materials contained in the present document (whether in full or in part) shall not be allowed until an appropriate permission of the copyright owner is obtained. Any unauthorized usage of materials contained herein may lead to civil liability and criminal prosecution in accordance with applicable laws.

Any eventual mentioning of other company names and equipment in the present document is made solely for the purpose of clarifying and describing the device operation and shall not infringe on the third party's intellectual property rights.

\***ZIGBEE** is the registered trademark of *ZigBee Alliance*; **iOS** is the registered trademark of *CISCO TECHNOLOGY, INC.*; **Android** is the registered trademark of *Google Inc.*; **Google Play** is the trademark of *Google Inc.*; **App Store** is the registered trademark of *Apple Inc.*; **Linux** is the registered trademark of *Linus Torvalds*.

## Responsibility and Technical Support

The present document is prepared in accordance with all necessary requirements and contains detailed information on the device installation, configuration and control valid as of the date of its issue.

*Perenio IoT* reserves the right to modify the device and make corrections or changes to this document without prior notice of the User, and shall not be responsible for any potential negative consequences which may arise from the use of an outdated version of the document, as well as for any possible technical and/or typographical errors, either omitted or accidental, or any related damage that may result from the document transfer or the use of devices.

*Perenio IoT* shall make no guarantee with respect to any data contained herein including but not limited to the device merchantability and fitness for a particular purpose.

For any technical issues, please contact your local *Perenio IoT* representative or the Tech Support Department at **perenio.com**.

The most common problems may be found in Section 7 of the present document and at **perenio.com** where you can also download the latest version of this Installation and Operation Manual.

Manufacturer:  
Perenio IoT spol s r.o.  
Na Dlouhem 79, Ricany – Jazlovice 251 01, Czech Republic  
**perenio.com**

## Conformance to Standards



The device is CE certified and complies with requirements of the following Directives of the European Union:

- 2014/53/EU Radio Equipment Directive (RED);
- 2004/30/EC Electromagnetic Compatibility Directive.



The device has passed all procedures of assessments established in Technical Regulations of the Customs Union and conforms with standards of the Customs Union



The device complies with the requirements of Restriction of the Use of Certain Hazardous Substances in Electronic and Electrical Equipment (2011/65/EU Directive)



The device complies with requirements of the Technical Regulations of the Republic of Belarus TR 2018/024/BY (Telecommunications. Security)



The national conformity mark of the Ukraine indicating that the device meets requirements of all applicable technical regulations



The device and supplied batteries must not be disposed of as a household waste in accordance with the Waste Electrical and Electronic Equipment Directive (2002/96/EC)

For the purpose of protection of the environment and human health, both the device and batteries must be disposed of in accordance with approved instructions on safe disposal. For more information on proper disposal, please contact your device supplier or local authorities responsible for waste management

BG	CZ	DE	ES	FR
GR	IT	KZ	LT	LV
NL	NO	PL	RO	RU
SE	SK	TR	UA	UK

Details on available Certificates are specified in Section 6 of the present document. For copies of Certificates and Reports, please visit a corresponding Section at **perenio.com**.

## Table of Contents

Introduction .....	3
Copyrights.....	3
Responsibility and Technical Support.....	4
Conformance to Standards.....	5
Table of Contents .....	6
1 General Description and Specifications.....	8
1.1 General Purpose.....	8
1.2 Technical Specification .....	10
1.3 Scope of Delivery .....	11
1.4 Packaging and Labelling .....	12
1.5 Safe Operation Rules .....	12
1.6 Standalone Operation of Perenio® Sensors .....	13
2 Installation and Setup .....	14
2.1 First Installation and Configuration .....	15
2.2 Sensor Control Panel .....	20
2.2.1 Battery Level.....	20
2.2.2 Event History .....	20
2.2.3 Additional Settings .....	21
2.2 Changing the Room or Location for the Sensor .....	22
2.3 History and Push-Notifications.....	23
2.4 Battery Replacement .....	24
3 Maintenance and Repair.....	25
4 Warranty Obligations.....	26
5 Storage, Transportation and Disposal of Devices .....	29
6 Other Information.....	30
7 Troubleshooting.....	32
8 Glossary .....	33

## Figures and Tables

Figure 1 – Smoke Sensor Exterior .....	9
Figure 2 – Buttons and Indicators.....	9
Figure 3 – Scope of Supply* .....	12
Figure 4 – Installation of the Smoke Sensor on a flat and sloping ceiling .....	16
Figure 5 – Fastening of the Smoke Sensor on screws or the 3M tape .....	16
Figure 6 – Disassembling the mounting bracket from the Smoke Sensor .....	17
Figure 5 – Add new device (Sensor) procedure.....	19
Figure 8 – Positioning of the battery in the Smoke Sensor.....	24
Table 1 – Basic Technical Specifications.....	10
Table 2 – Typical Errors and Troubleshooting Methods.....	32

## Connection to the Perenio Smart Mobile App

A. SWITCHING ON AND INSTALLATION OF THE PECSS01 SMOKE SENSOR: .....	15
B. LOGIN TO THE EXISTING USER ACCOUNT .....	17
C. CONNECTION TO THE CONTROL GATEWAY/IOT ROUTER .....	18

## 1 General Description and Specifications

### 1.1 General Purpose

The **Perenio® PECSS01** Photoelectric Sensor is a Zigbee-based device intended to detect visible smoke particles (flameless stage). It is used as part of the **Perenio Smart Building Management System** and provides for timely alert in the event of smoke in the room.

The principle of operation is based on the Sensor triggering in the case of IR light scattering when visible smoke particles enter the detector area, which increases the accuracy of ignition source detection.

**NOTE.** The Smoke Sensor is NOT intended to detect gas, flame and high temperatures, as well as to extinguish fire.

**ATTENTION!** The Smoke Sensor is not a fire detecting device and transmits no alarms to fire automatics devices or the fire department control panel. It is designed to provide an audible signal in case of detection of increased concentrations of smoke, vapor and dust particles in the area of installation.

The **PECSS01** Smoke Sensor has a number of distinctive features, namely:

- High alarm level (up to 85 dB/3 m);
- Timely detection of smoke;
- iOS and Android smartphone compatibility;
- Support of Zigbee;
- Ultra-low power consumption (up to 3 years of operation with one battery);
- Impact- and heat-resistant casing material;
- Installation using 3M Tape or screws;
- Standalone operation;
- Small size and stylish design.





Figure 1 – Smoke Sensor Exterior

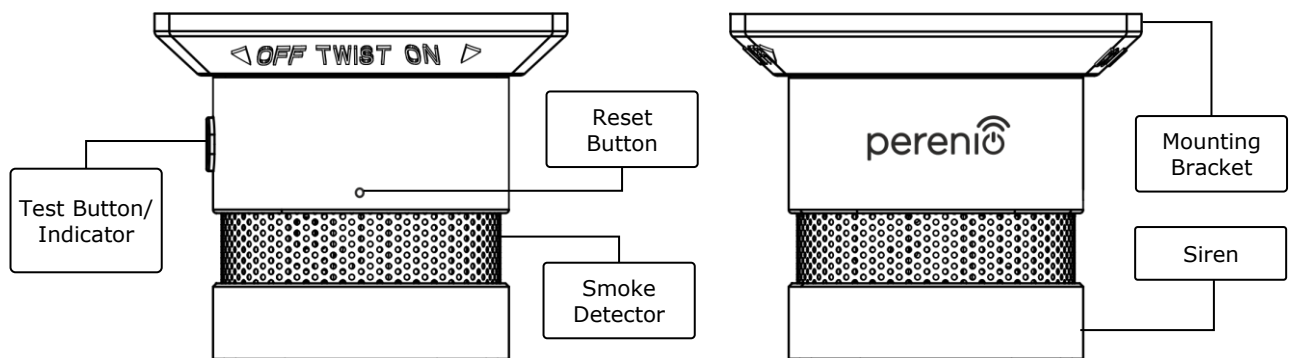

Figure 2 – Buttons and Indicators

## Buttons, Ports and Indicators

### Test Button/ Indicator

When pressed once, the beep sounds in the standby mode (It is used to check normal operation of the device). It is also used as the Sensor status indicator

### Smoke Detector

The smoke catching section of the Sensor

### Mounting Bracket

It is designed for mounting the Smoke Sensor on screws (Mounting holes available) or the 3M Tape

### Reset Button

It is used to reset Smoke Sensor settings, as well as for the Smoke Sensor to be detected by the Control Gateway/IoT Router

### Siren

A signaling device that emits sound in the case of smoke in the room

**ATTENTION!** All Products and the Mobile Application of the Company (including any future software and hardware whether in-house or third-party developed) are not intended for emergency responses and cannot be used as fire-extinguishing equipment and/or for emergency intervention, including but not limited to fires, flooding, gas leaks or explosions, burglary and theft, as well as natural disasters and other force majeure circumstances leading to damage and/or losses incurred by the Client or caused to their estates, personal property and/or other products, devices, personal data and privacy.

## 1.2 Technical Specification

Table 1 – Basic Technical Specifications

Parameter	Value
Article	PECSS01
Microprocessor	Silicon Labs EM3586 (Zigbee IC)
Communication Technology	Zigbee HA 1.2 (IEEE 802.15.4)
Operating Frequency	2.4GHz to 2.5GHz
Connection Radius	up to 40 meters (open area)
Zigbee Antenna	Type: Built-in Transmitting Power: -26dBm to +8dBm Receiver Sensitivity: -102dBm Antenna Gain: 0.5dBi Repeater: N/A
Alarm Indication	Red LED
Alarm Type	Siren, light indication
Alarm Level	up to 85dB (at a distance of 3 meters)
Sensitivity	0.089dB/m to 0.25dB/m
Standalone Operation	Available
Power Type	CR123A Battery (1500mAh, 3V), 1 pc.
Power Consumption	Standby Mode: not more than 0.01mA Alarm Mode: not more than 60mA

Parameter	Value
Battery Level	Yes (Available in the Mobile App)
Operating Temperature	0°C to +50°C
Operating Humidity	1% to 95% (non-condensing)
Storage Temperature	-10°C to +50°C
Storage Humidity	1% to 95% (non-condensing)
Installation	On a flat surface (Screws, 3M Tape). For indoor installation only.
Casing Material	ABS/PC
Color	White
Dimensions (L x W x H)	60 mm x 60 mm x 49.2 mm
Weight	49.7 g (70.2 g with accessories)
Warranty Period	24 months
Service Life	24 months
Certification	CE, EAC, RoHS, UA.TR

### 1.3 Scope of Delivery

The following items and accessories are supplied within the **Perenio<sup>®</sup> PECSS01** Smoke Sensor package:

1. PECSS01 Smoke Sensor (1 pc.)
2. Battery (CR123A) (1 pc.)
3. Screws and dowels (1 set)
4. Reset pin (1 pc.)
5. 3M tape (1 pc.)
6. Quick Start Guide (1 pc.)
7. Warranty Card (1 pc.)
8. Sticker (1 pc.)



**Figure 3 – Scope of Supply\***

\* Images of accessories are provided for informational purposes only

## 1.4 Packaging and Labelling

The **Perenio® PECSS01** Smoke Sensor is supplied in an individual blister package of 171 x 126 x 57 mm (L x W x H) containing the full name and marking of the device, the list of accessories provided and basic technical specifications thereof, as well as the date of manufacture and information about the Manufacturer of devices.

Weights of the blister package are as follows:

- Net weight: 70 g;
- Gross weight: 110 g.

## 1.5 Safe Operation Rules

For the proper and safe operation of **Perenio®** Sensors, follow the instructions and safety procedures described in the present Manual. The Manufacturer shall not be liable for any damage caused as a result of improper operation of devices.

### Safe Operation Conditions

1. The device shall be installed indoors only.
2. Do not install the Sensor in rooms with high level of humidity, insects, dust and/or grease, as well as near air conditioners, ceiling fans and extract systems, including heaters and fluorescent lamps.
3. Avoid installing the Sensor in the kitchen, garage, boiler room, etc., as they are subject to the accumulation of combustion products.
4. The Users shall observe storage/transportation conditions, as well as the operating temperature mode of the device as declared by the Manufacturer.

5. The Users shall observe recommendations on ceiling installation (See Figure 4).
6. The User must not disassemble or attempt to repair the device on their own.
7. The User must not drop, throw or bend the device.
8. In order to avoid personal injury, it shall not be allowed to use the cracked or in any other way damaged device.
9. Use dry cloth or cloth soaked in a small amount of water for cleaning (don't use harsh chemicals/cleaning agents). The device must be powered off before cleaning.
10. Children shall not be allowed to use the device unsupervised and/or play with it.

## **1.6 Standalone Operation of Perenio<sup>®</sup> Sensors**

The Control Gateway/IoT Router is not necessarily required for all **Perenio<sup>®</sup>** Sensors in order to alert Users on potentially dangerous situations.

So, the Smoke Sensor can operate as a standalone device, i.e. when it detects smoke in a room, it will beep.

However, to receive notifications on a smartphone and run active scenarios, the User must have an installed mobile app and an activated Control Gateway/IoT Router, as well as unite the above devices in a system.

## 2 Installation and Setup

Before installation, the User shall select one of the following possible locations and mounting modes for the device:

- On a horizontal surface (ceiling);
- Using 3M mounting tape or screws.

The User shall also make sure that the selected location meets the following requirements:

- The selected location is a potential fire hazard area and it does not contain high levels of vapor, dust and grease;
- Flat and stable surface in the installation site of the Sensor.

**NOTE.** It is not recommended to install the device in areas with a high level of noise and a high-frequency interference. Reinforced concrete floors may reduce the distance of wireless signal transmission.

It is recommended to install the Smoke Sensor at a minimum distance from the Control Gateway/IoT Router.

For installation of the Smoke Sensor using 3M tape (for example, on a ceiling), it is necessary to prepare the surface as follows:

1. Wipe the surface of the Sensor to which the 3M tape will be attached with alcohol and wait until it is dry.
2. Attach the 3M tape to the Sensor surface.
3. Make sure that the place of the Sensor installation is free from dust, dirt, etc.
4. Wipe the surface to which the 3M tape will be attached with alcohol and wait until it is dry.
5. Attach the device in the place of installation using the 3M tape.

The entire process of setting-up the Sensor can be divided into several key stages:

- Logging in to the User Account of the **Perenio Smart** Mobile App;
- Checking for the availability of the CG/IoT Router connected to the mains and the Internet;
- Connection of the Sensor to the Control Gateway/IoT Router.

## 2.1 First Installation and Configuration

In order to connect the Smoke Sensor to the Control Gateway/IoT Router via the **Perenio Smart** Mobile App, it is necessary to perform the following steps:

1. Unpack the Sensor and power it on (See par. **A** below).
2. Login in to the **Perenio Smart Building Management System** User Account (See par. **B** below).
3. Connect the Smoke Sensor to the Mobile App (See par. **C** below).
4. Enter the desired Sensor name and select the Room of installation.
5. Install the Sensor in the selected room.

### A. SWITCHING ON AND INSTALLATION OF THE PECSS01 SMOKE SENSOR:

To install the **PECSS01** Smoke Sensor, follow steps below:

1. Unpack the device.
2. Select the installation place and method as follows:
  - a. *Installation Place*: On a flat/sloping ceiling or a suitable vertical surface;
  - b. *Installation Method*: Using the 3M tape or screws.

**NOTE.** When installing the Smoke Sensor on the ceiling, you should keep it at a distance of at least 30 cm from lamps and decorations, as well as at a distance of at least 15 cm from walls and corners (See Figure 4).

If the length of the room exceeds 9 meters, it is recommended to install two Smoke Sensors (one on each side of the room).

Do not install the Sensor in rooms with high level of humidity, insects, dust and/or grease, as well as near air conditioners and ceiling fans.

Replace the Smoke Sensor at least once every ten (10) years, even if it is not damaged.

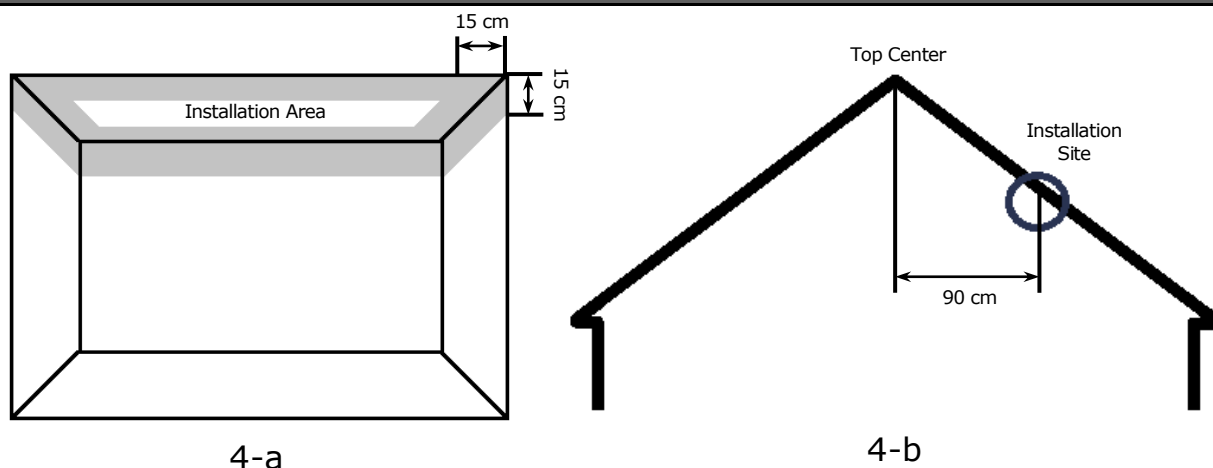

**Figure 4** - Installation of the Smoke Sensor on a flat and sloping ceiling

**Flat Ceiling  
Installation**  
(Figure 4-a)

It is recommended to install the Smoke Sensor in the central part of the ceiling, since smoke, heat and combustion products rise up first and then dissipate to sides

**Sloping Ceiling  
Installation**  
(Figure 4-b)

It is recommended to install the Smoke Sensor at a distance of 90 cm in a horizontal direction from the top of the sloping ceiling

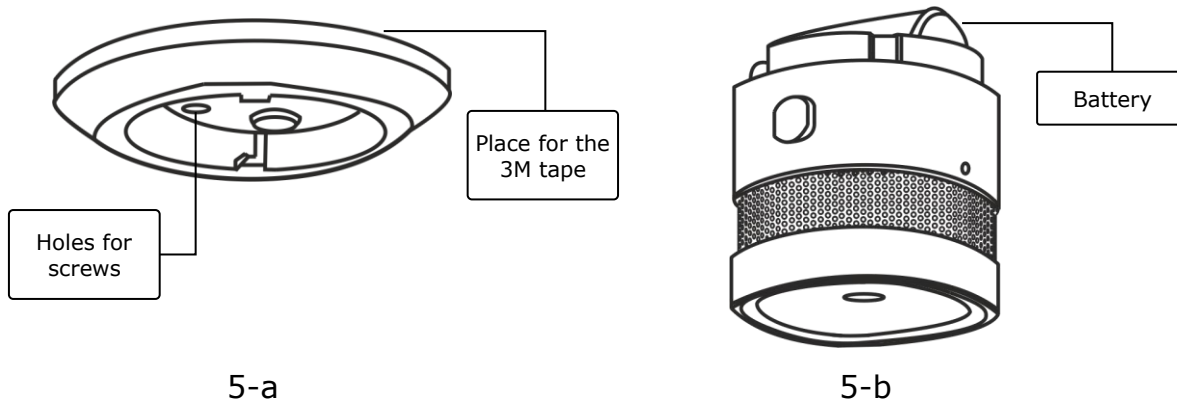
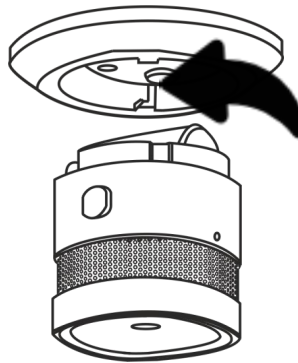

**Figure 5** - Fastening of the Smoke Sensor on screws or the 3M tape

3. Disassemble the mounting bracket by turning it counterclockwise as shown in Figure 6.
4. Mount the bracket in the required area using screws or glue it onto the 3M tape supplied with the Smoke Sensor.
5. Switch on the Smoke Sensor by removing the battery isolation strip.
6. Reassemble the Smoke Sensor and the mounted bracket.



**NOTE.** If the LED starts flashing slowly after removal of the battery isolation strip, you can immediately begin connecting it to the Control Gateway/IoT Router and skip **Step d** of par. C. "CONNECTION TO THE CONTROL GATEWAY/IOT ROUTER".



**Figure 6** – Disassembling the mounting bracket from the Smoke Sensor

After the above Steps 1-6 are successfully completed, the Smoke Sensor is considered to be installed and ready for operation.

It is recommended to test the Smoke Sensor at least once a week. To do this, press the Test Button (see Figure 2) until the signal sounds.

## B. LOGIN TO THE EXISTING USER ACCOUNT

- Enter your e-mail address and password in the login screen.
- Click on the **LOG IN** button.

**NOTE.** If the password was lost, the User can restore it by clicking on a corresponding link on the screen.

To restore a forgotten password, use the e-mail address linked to your User Account, to which instructions on changing the password will be sent.

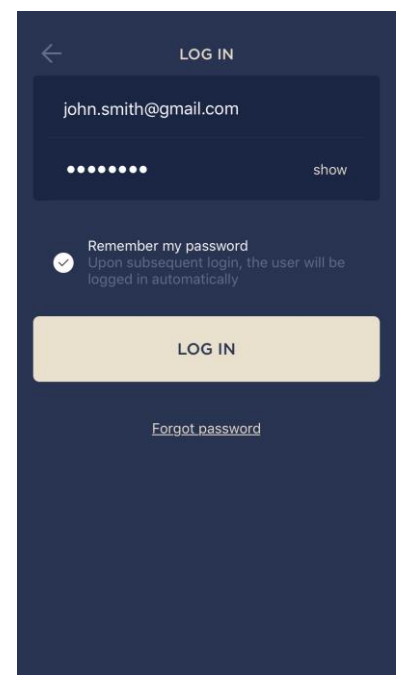

## C. CONNECTION TO THE CONTROL GATEWAY/IOT ROUTER



- a. Click on the "+" icon in the upper right corner of the Devices tab and select the Sensor in the list;
- b. Select the Control Gateway/IoT Router to which the Sensor shall be connected (This screen will be displayed, only if there are several Control Gateways/IoT Routers activated in the User Account).

**NOTE.** The Control Gateway/IoT Router must be connected to the mains and the Internet, as well as activated in the Perenio Smart App.

- c. Start searching for Sensors;
- d. If the LED flashes slowly after the first power on of the device, proceed to the **Step e**, otherwise press and hold the reset button until the LED Indicator starts blinking rapidly. Wait for the indicator to go off, then press and hold the reset button until the LED Indicator starts blinking.

**NOTE.** Several sensors may be connected to the Control Gateway/IoT Router at once.

- e. After successful connection, enter the Sensor's name and select the Room.

### C.1. CONNECTION ERRORS

The connection failure of the device may occur due to one of the following reasons:

- a. The device is switched off or at a too long distance from the Control Gateway/IoT Router (4.5 meters);
- b. The Control Gateway/IoT Router is offline;
- c. The LED Indicator was blinking fast before start of the sensor connection (You should remove the sensor battery and insert it back into the casing).

**NOTE.** To eliminate connection failures, follow instructions specified on corresponding screens of the smartphone.

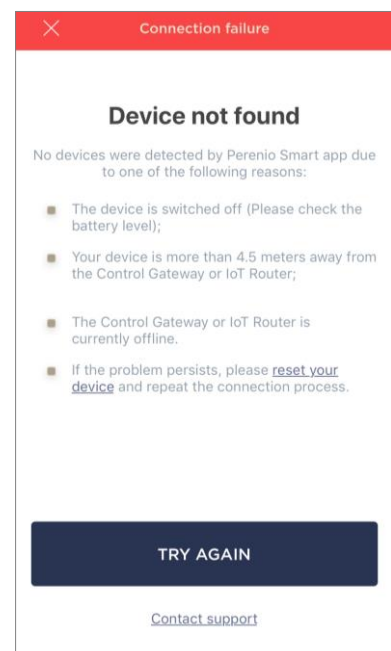

The entire process of the Sensor connection in the Mobile App is shown below.

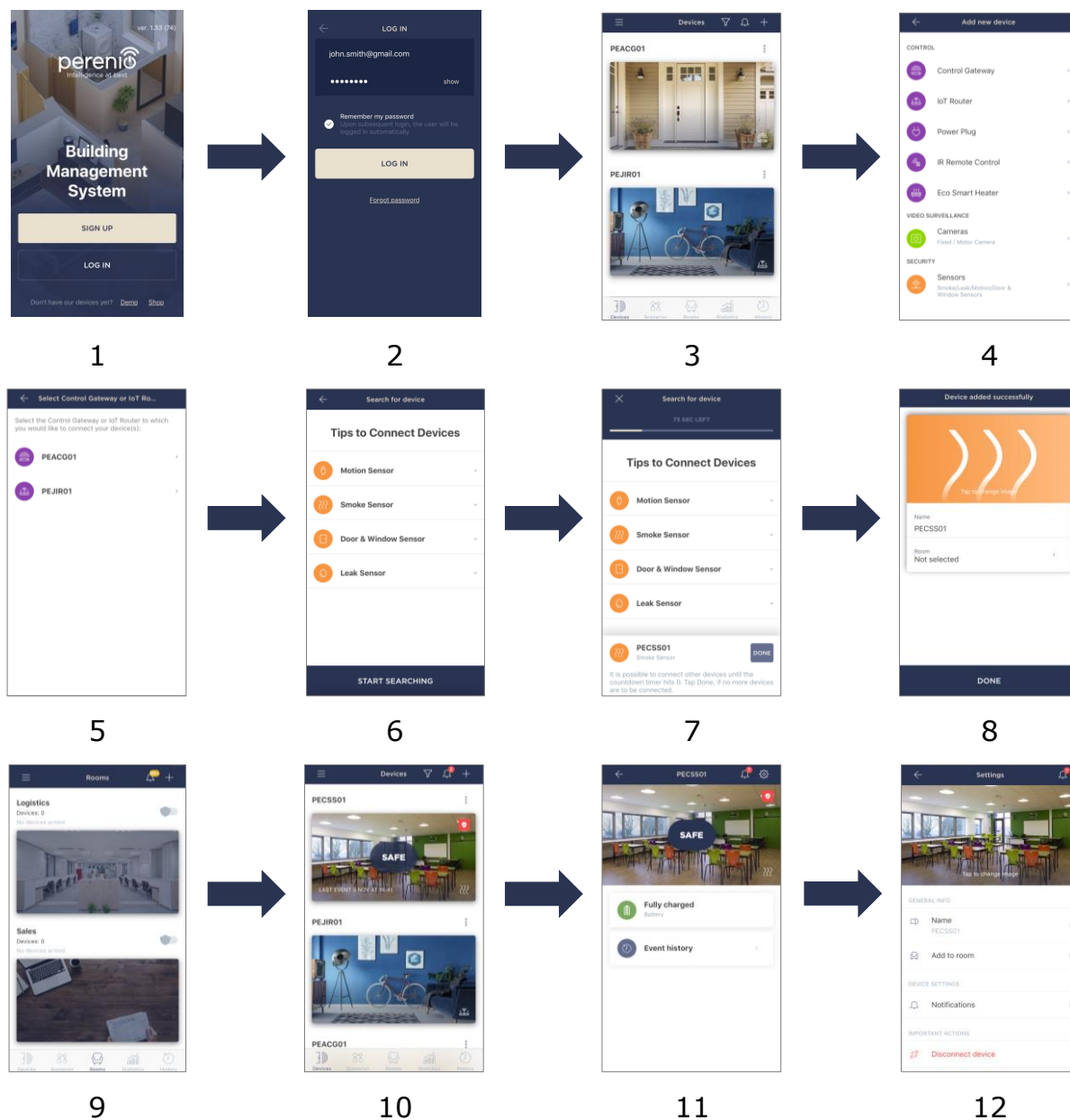

**Figure 7 – Add new device (Sensor) procedure**

## 2.2 Sensor Control Panel

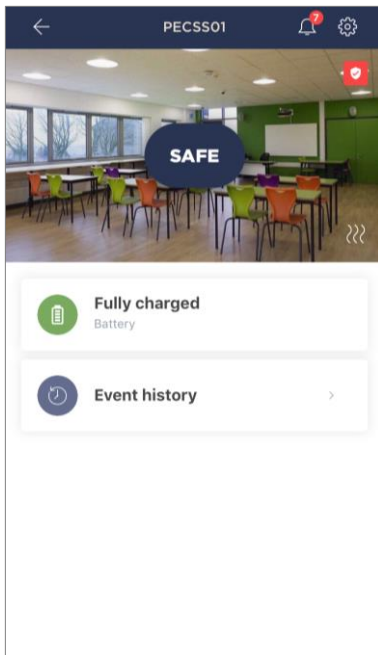

The Sensor control panel is displayed, when you click on its image in the list of connected devices in the "Devices" tab.

The user can perform the following actions in this control panel:

- View the current state of the device;
- View the battery level;
- View the history of events;
- Make additional setting of the sensor.

**NOTE** that it is not possible to turn off the Armed Mode for the Smoke Sensor.

### 2.2.1 Battery Level

The battery level is displayed in the following four (4) levels:

- Fully charged (100% to 95%);
- High level of charge (94% to 75%);
- Average level of charge (74% to 31%);
- Low level of charge (30% to 11%);
- Discharged (10% to 0%).

**NOTE** that it is recommended to purchase additional batteries in advance to ensure stable operation of the sensors.

### 2.2.2 Event History

In this tab, the user can view the status of the sensor, as well as the time when the event occurred.

Functions are as follows:

- “ENTIRE HISTORY” filter, which allows viewing the following events:
  - Changes in the security modes (“Armed”, “Disarmed”);
  - Device actuation events (“Safe”, “Danger”);
  - Notifications about low battery level;
  - Start and completion of the firmware update.
- “ALARMS ONLY” filter, which displays device actuation events for the Armed Mode only;
- Filter by date.

**NOTE** that the number of days available for viewing depends on the Subscription Plan (It is 7 days for free Subscription).

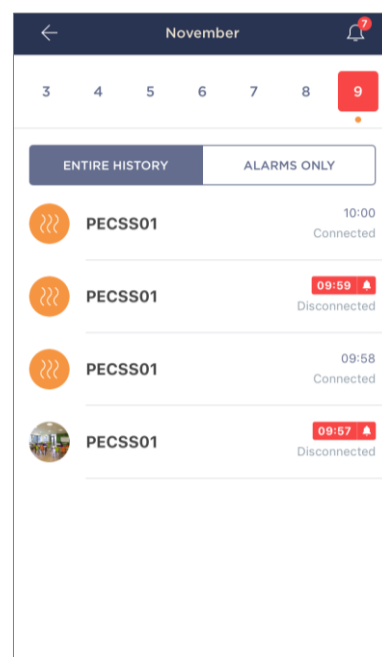

## 2.2.3 Additional Settings

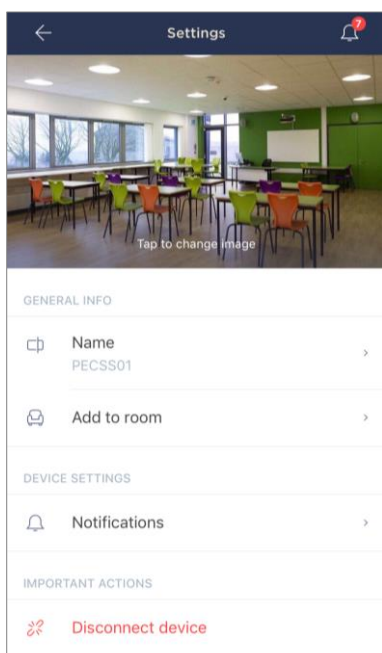

After the Sensor is activated in the Perenio Smart app, the user can make the following settings remotely:

- Change or upload the device image for easier identification of the sensor in the list of connected devices;
- Change the name of the device;
- Add a device to the Room or change the Room of installation;
- Turn on the sound of push notifications;
- Remove the device from the mobile application.

There are two ways to switch to the settings screen, namely:

1. Click on the icon with three dots in the right upper corner of the sensor image in the mobile application and select "Settings".

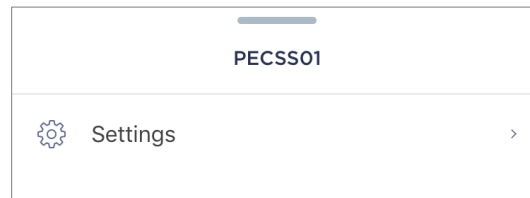

2. In the control panel, click on the settings icon.



## 2.2 Changing the Room or Location for the Sensor

When using the Sensor, it may be necessary to change its installation area. The following options are possible:

- 1. Change the room/location** (The CG/IoT Router remains the same) as follows:
  - a. Demount the Sensor and move it to another room;
  - b. Make sure that the Sensor is at an allowable distance from the CG/IoT Router;
  - c. Install the Sensor in a new room (Use a new 3M tape, if required);
  - d. Change the Room in Sensor settings in the User Account.
- 2. Change the room/location** (Connection to another CG/IoT Router is required) as follows:
  - a. Login in to the Perenio Smart app and select the Location where the Sensor is activated;
  - b. In the Devices tab, select the required Sensor from the list and click on the  icon (Settings);
  - c. In the pop-up window, choose "Disconnect device";
  - d. Demount the Sensor and move it to another room/location;
  - e. Make sure that the Sensor is at an allowable distance from the CG/IoT Router;
  - f. In the User Account, select the Location where you want to move the Sensor;

- g. Initiate the Sensor search by the Control Gateway/IoT Router through the Perenio Smart application according to par. **C. "CONNECTION TO THE CONTROL GATEWAY/IOT ROUTER"**;
- h. Install the Sensor in a new room (Use a new 3M tape, if required).

**NOTE.** The User can manually disconnect the Sensor from the Control Gateway/IoT Router. To do this, press and hold the Reset button on the Sensor until the LED flashes (It usually takes no more than 5 seconds).

To check that the Sensor was successfully disconnected, you should update the list in the Devices tab (Pull the screen down until the progress icon appears and the data is updated). If the sensor is disconnected, it will disappear from the list of connected devices.

## 2.3 History and Push-Notifications

All notifications and other messages including changes in **Perenio**<sup>®</sup> device statuses are displayed in the History tab. At the same time, the most important events are shown online in the notification window (🔔) in the User Account. Available types of notifications are as follows:

- Alarms (These are always received like push-notifications on a smartphone, as well as recorded in the notification window and in the History tab in the Mobile Application);
- Important messages (These are recorded in the notification window in the Armed Mode, as well as always recorded in the History tab);
- Standard events (These are recorded in the History tab only).

**Alarms.** The most important messages such as device actuation notifications when in the Armed mode, including all alarms from both the Smoke Sensor and the Leak Sensor (even if in the Disarmed mode), as well as changes in the Control Gateway/IoT Router Online/Offline status.

**Important messages.** Notifications of the start and completion of the Control Gateway/IoT Router firmware update process, as well as low battery notifications and changes of the Armed/Disarmed mode for the Location.

**Standard events.** Various news and other information from *Perenio IoT*, as well as alerts from both the Door&Window Sensor and the Motion Sensor when in the Disarmed mode.

## 2.4 Battery Replacement

The Smoke Sensor can operate with one battery for a period of up to three (3) years. The battery level can be controlled via the Mobile App (Smoke Sensor panel).

In order to properly replace a discharged battery, the User observe the following rules:

- Unscrew the Smoke Sensor from the mounting bracket;
- Make sure that the new battery is the same as the original (supplied with the Sensor);
- When replacing the battery, the User shall observe the polarity (See Figure 8).

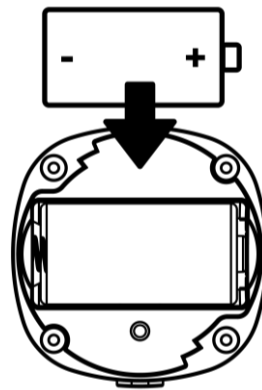

**Figure 8** – Positioning of the battery in the Smoke Sensor

After battery replacement, the LED of the Smoke Sensor will blink.



### 3 Maintenance and Repair

The **Perenio<sup>®</sup> PECSS01** Smoke Sensor does not require special maintenance in the normal course of operation. However, in order to maintain the proper state and stable operation of the device it is recommended to perform the following actions from time to time:

- Clean the device casing from dirt and dust at least once every six months;
- Test the alarm signal of the Sensor at least once a week;
- Replace the Sensor every ten (ten) years regardless of damages;
- Check for updates of the Perenio Smart app;
- Check for battery condition and replace it in a timely manner;
- Repair mechanical damages to devices (in Service Centers).

The **Perenio<sup>®</sup> PECSS01** Smoke Sensor repairs shall be carried out in Service Centers, because casings will have to be opened in the case of any element failure.

In the case of warranty repairs or replacement, the User shall provide the Seller with the sales receipt and the purchased device.

For details on the replacement and repairs of the **Perenio<sup>®</sup>** Smoke Sensor, please contact your local Company representative or the Tech Support Department at **perenio.com**.

## 4 Warranty Obligations

The warranty period for the Smoke Sensor shall be **Twenty-Four (24) months** from the date of sale to the End User. General-purpose batteries (such as AAA, CR123A, CR2450, etc.) shall not be covered by the warranty of the Manufacturer of IP Cameras, gateways, IR remote controls and sensors.

The Warranty Card shall be deemed valid provided that it is correctly and completely filled in by the Seller. Upon the purchase, the Customer shall check that both the Serial Number and the Model name of the device correspond to those indicated in the Warranty Card.

Incomplete or illegible Warranty Card shall be deemed not valid. In this case, it is recommended to contact the Seller and ask for a duly filled in Warranty Card. It shall be also allowed to provide the original of the sales/cashier's receipt or such other documentary evidence of the fact and the date of sale of the device. The date of sale shall be the date indicated on the sales/cashier's receipt or other relevant document. If the date of sale is not possible to be determined, the start of the warranty period shall be the date of manufacture of the device.

The Manufacturer shall guarantee that all materials, components and assemblies of **Perenio®** devices are free from defects under normal operation within the warranty period. The limited warranty shall be applied to the first End Customer of **Perenio®** devices only and cannot be transferred to a subsequent customer.

For warranty replacement, the device must be returned to the Seller along with its receipt. Warranty obligations for **Perenio®** devices shall be provided in the country of their purchase only.

### WARRANTY SERVICE PROCEDURE

In the case of any alleged defect or deficiency of the device detected, the Customer shall contact the Authorized Service Center before the warranty period expiration and provide the following:

1. The device with an alleged defect or deficiency.
2. The Warranty Card filled out in accordance with the applicable legal requirements, or the original of the document confirming the purchase of the device, including clear indication of the name and the address of the Seller, as well as the date when this device was sold.

## **LIMITATION OF LIABILITY**

**Perenio<sup>®</sup>** devices SHALL NOT BE SUBJECT TO a free warranty service in the case of identification of at least one of the following damages or defects:

- Any damage caused by force majeure, accidents, and willful or careless acts (omissions) of the Customer or third parties;
- Any damage caused by the impact of other objects including but not limited to exposure to moisture, dampness, extreme temperatures or environmental conditions (or jumps in such conditions), corrosion and oxidation, as well as penetration of food or liquid, and the effects of chemicals, animals, insects and byproducts thereof;
- In the event when the device (accessories and/or components) was unsealed (the seal integrity was violated), modified or repaired by any party other than the Authorized Service Center, including repair works using unauthorized spare parts;
- Any defects or damage caused by improper or unintended use of the device, including operation contrary to available manuals;
- Any defects caused by attempts to connect to incompatible software;
- Any defects caused by natural wear and tear of Products, including bags, casings, batteries or Installation and Operation Manuals;
- In the event when the Serial Number (Name Plates), the date of manufacture or the Model name on the device casing was in any way removed, erased, affected, altered or made illegible;
- In the case of violation of operating procedures and conditions, as well as the device installation instructions described in relevant Manuals;
- Cracks, scratches and other defects caused as a result of transportation and/or operation of the device by the Customer or acts of negligence on their part;
- Mechanical damages that occurred after transferal of the device to the Customer including damage caused by sharp objects, bending, squeezing, falling, etc.;
- Any damage caused by non-conformity with the standards of power supply, telecommunication and cable networks or similar external factors.

THE PRESENT LIMITED WARRANTY IS AN EXCLUSIVE AND THE ONLY PROVIDED GUARANTEE THAT SHALL REPLACE ANY OTHER EXPRESS AND IMPLIED GUARANTEES. THE MANUFACTURER SHALL PROVIDE NO GUARANTEES, WHETHER EXPRESS OR IMPLIED, BEYOND THE DESCRIPTION CONTAINED IN THE PRESENT DOCUMENT, INCLUDING THE IMPLIED WARRANTY OF MERCHANTABILITY AND FITNESS FOR A PARTICULAR PURPOSE. THE CUSTOMER MAY USE DEFECTIVE OR INAPPLICABLE DEVICE AT HIS/HER OWN DISCRETION. THE MANUFACTURER SHALL NOT BE RESPONSIBLE FOR DAMAGE TO OTHER PROPERTY CAUSED BY DEVICE DEFECTS, THE LOSS OF USABILITY OR TIME OR FOR ANY SPECIAL, INCIDENTAL, INDIRECT OR CONSEQUENTIAL DAMAGE OR LOSS INCLUDING BUT NOT LIMITED TO COMMERCIAL

LOSS, LOSS OF PROFITS, LOSS OF CONFIDENTIAL OR OTHER INFORMATION, AS WELL AS DAMAGES CAUSED BY BREAKS IN COMMERCIAL OR PRODUCTION ACTIVITIES DUE TO THE FACT THAT THE DEVICE WAS RECOGNIZED AS FAULTY, DEFECTIVE OR NOT ALLOWED FOR USAGE.

The present limited warranty shall provide the Customer with certain legal rights. The Customer may also have other rights in accordance with the local consumer protection laws that vary from country to country and may not coincide with this limited warranty. For full understanding of the Customer's rights, you shall read local acts.

**NOTE.** The Manufacturer does not produce equipment for *Vital Tasks*. Vital Task Products shall include life support systems, medical equipment, implantation-related medical devices, commercial transportation, nuclear equipment or systems, and any other fields of application where equipment failures may do harm to a humans' health or cause their deaths, as well as result in a property damage.

## 5 Storage, Transportation and Disposal of Devices

The **Perenio**<sup>®</sup> Smoke Sensor may be shipped by any kind of covered vehicles (by rail, or road or in sealed heated airplane compartments, etc.) in accordance with the requirements of current regulatory documents applicable to fragile goods sensitive to moisture.

Similar conditions shall apply to the device storage at the Seller's warehouse.

It is also required to comply with the temperature and humidity conditions of storage and operation specified in the Table of technical specifications of the present Manual.

For disposal of devices and/or batteries, the User shall observe rules of the Directive on Waste Electrical and Electronic Equipment (WEEE) according to which all electric and electronic products, as well as batteries must be disposed of separately at the end of their service life. Such devices and accessories must not be disposed of together with unsorted municipal waste due to their potential to cause harm to the environment.

For the device disposal purposes, it shall be returned to the point of sale or to the local processing center.

For detailed information on recycling of the present device, please contact your waste management company.

**NOTE.** The User must comply with the temperature and humidity conditions of storage and transportation specified in the Table of technical specifications of the present Installation and Operation Manual.

## 6 Other Information

### Manufacturer

Name	<i>Perenio IoT spol s r.o.</i>
Address	Na Dlouhem 79, Ricany – Jazlovice 251 01, Czech Republic
Contact Info	perenio.com, info@perenio.com

### Importing Company

#### Croatia

Name	<i>ASBISc-CR d.o.o.</i>
Address	Slavonska avenija 24/6, 10000 Zagreb, RH

#### Czech Republic

Name	<i>ASBIS CZ, s.r.o.</i>
Address	Obchodní 103, Čestlice, 25101

#### Poland

Name	<i>ASBIS POLAND Sp. z o.o.</i>
Address	Ul. Krasnowolska, 17A, 02-849 Warszawa

#### Other EU Countries

Name	<i>SIA ASBIS BALTICS</i>
Address	Latvia, Riga, Bauskas street 58a, LV-1004

### Quality Claims Acceptance and Warranty Service Company

#### Croatia

Name	<i>ASBISc-CR d.o.o.</i>
Address	Slavonska avenija 24/6, 10000 Zagreb, RH

#### Czech Republic

Name	<i>ASBIS CZ, s.r.o.</i>
Address	Obchodní 103, Čestlice, 25101

Poland

Name	<i>ASBIS POLAND Sp. z o.o.</i>
Address	Ul. Krasnowolska, 17A, 02-849 Warszawa

Other EU Countries

Name	<i>SIA ASBIS BALTICS</i>
Address	Latvia, Riga, Bauskas street 58a, LV-1004

**Info on Certificates and Declarations**

Certificates	Certificate of Constancy of Performance #1008-CPR-MC 69257986 0001 as of November 10, 2017
Declarations, Reports	TUV Test report #50102219 001 as of September 29, 2017 (EN 15604:2005/AC:2008)

Addresses of Service Centers are available at [perenio.com](http://perenio.com) in the 'Support' Section.

## 7 Troubleshooting

Table 2 below shows typical errors and problems that may occur in the process of connection and configuration of the Smoke Sensor.

Table 2 – Typical Errors and Troubleshooting Methods

Item No	Problem	Possible Reasons	Solution
1	An alarm immediately after the sensor is powered on	High dust content of the sensor or high vapor content in the air	Clean the sensor from dust or ventilate the room
2	Short beeps after the sensor is powered on, as well as absent or faint alarm	Low battery level of the sensor	Change the battery
3	Absent or poor alarm	Low battery level of the sensor	Change the battery
4	No alarm after pressing the test button	The battery is improperly inserted	Observe the polarity of the battery in the sensor
		Low battery level of the sensor	Change the battery



## 8 Glossary

<b>3M Tape</b>	Double-sided mounting tape which is a rubber or acrylic adhesive applied on both sides of the foam. It is used in order to avoid drilling holes and using fasteners
<b>ABS</b>	Modern synthetic polymer with a high level of impact resistance and elasticity
<b>CG</b>	The <b>Perenio</b> <sup>®</sup> PEACG01 Control Gateway
<b>DSP</b>	The Digital Signal Processor is a special microprocessor designed to ensure digitized signal handling (usually, in real time mode)
<b>IoT</b>	The Internet of Things is a system of Internet-connected devices able to collect and exchange data coming from built-in services
<b>Location</b>	General term which means a building or a structure in which <b>Perenio</b> <sup>®</sup> Cameras, Control Gateways/IoT Routers and/or Sensors are installed
<b>Perenio Smart</b>	Software developed by <i>Perenio IoT</i> for remote control of wireless Cameras from smartphones
<b>Viewing Angle</b>	The area that falls into the field of viewing of the Sensor
<b>Zigbee</b>	A network protocol designed for secure transmission of data at low speeds, which is recognized for an extremely low power consumption